

APPLY LUBRICANT TO ALL SEALS
PRIOR TO INSTALLATION.
DO NOT USE SILICONE TYPE LUBRICANTS.
FOR PROPER ARM MOUNTING SEE IS1505.

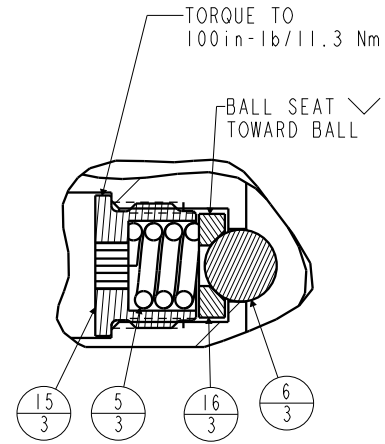

DETAIL A
SCALE 1:500

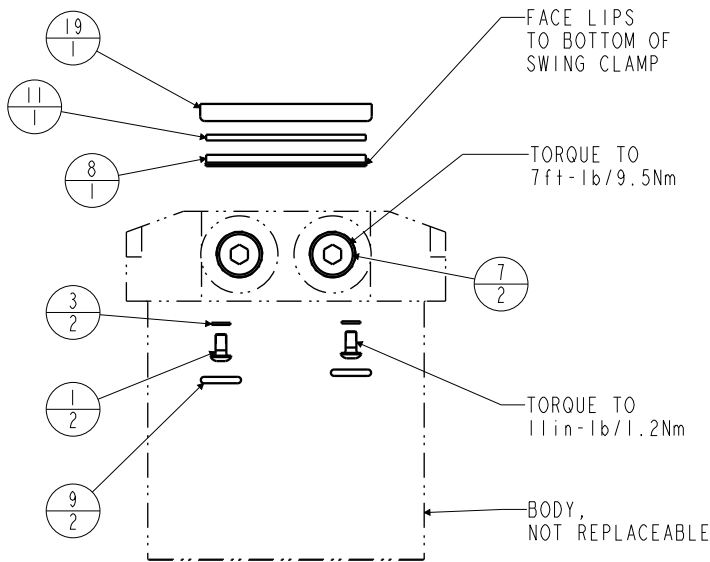
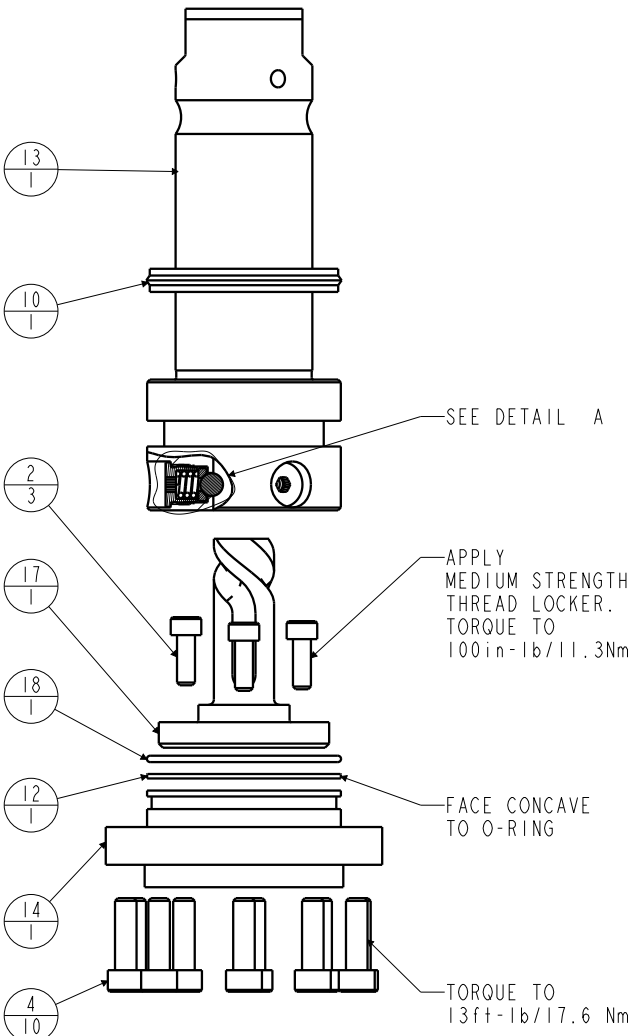

No.	QTY	PART No.	DESCRIPTION	Std Seal Kit	FKM Seal Kit
N/A	N/A	IS1505	INSTRUCTION SHEET, ARM INSTALLATION		
N/A	N/A	6V711036	SEAL KIT, FKM		
N/A	N/A	60711036	SEAL KIT, STANDARD		
19	1	39V11051	WIPER, PRESS-IN, (1-1/2)	X	X
18	1	39H51002	O-RING, (-033)	X	39V51002
17	1	81592122	CAM, SC, LP, 7500/33KN, LH, TC		
16	3	81532108	SEAT, BALL, SC, LP, TC		
15	3	81532107	RETAINER, SC, LP, TC		
14	1	81532105	CAP, END, SC, LP, 33KN/7500		
13	1	81512111	PLUNGER, SC, LP, 7500/33KN, DA, TC		
12	1	39054017	BU RING, (-033)	X	39054023
11	1	39054016	BU RING, (1.5x.125x.063)	X	X
10	1	39052030	SEAL, CROWN, 1-3/4x2-1/8x1/4	X	39V52030
9	2	39050042	O-RING, (-011)	X	39051025
8	1	39011075	SEAL, LL, (1-1/2 X 1/8 X 1/8 1-3/4)	X	39V11075
7	2	30601144	PLUG, SOCH, SAE 4		
6	3	23650004	BALL, TUNGSTEN-CARBIDE. 250		
5	3	23350066	SPRING, COMPRESSION		
4	10	21500304	SHCS, M6 X 1.0-6G X 20MM		
3	2	21500200	WASHER		
2	3	21500031	SHCS, M5 X 0.8 X 14, ALY		
1	2	21500019	SCREW, CAP, BTNH, M3 X 6, ALY		

PARTS LIST



VEKTEK, INC.
1334 E. SIXTH AVE. P.O. BOX 625
EMPORIA, KS. 66801 U.S.A.

ASSEMBLIES AFFECTED

14062101
14062101F

PARTS LIST, ASSY, SC, LP, TC, TF, 7500, DA, LH

SIZE
A

PL7155

REV
C

SHEET 1 OF 1

FORM FEG035_PL_ASIZE, REV. B

C	5762	RELEASE	JDW	07/15/25
REV	IN ACCORDANCE WITH ECN	EFFECTIVE DATE	REVISED BY	DATE
DRW BY:	JDW	DRAWING STATUS: Released		
DATE:	6-7-11	PRODUCTION APPROVED FOR RELEASED STATUS ONLY		

